

Jumping Finite Automata

Petr Zemek

Brno University of Technology, Faculty of Information Technology
Božetěchova 2, 612 00 Brno, Czech Republic
<http://www.fit.vutbr.cz/~izek>



Based on

 Alexander Meduna and Petr Zemek

Jumping Finite Automata

International Journal of Foundations of Computer Science

Vol. 49, No. 2, p. 1555–1578, 2012

2nd Annual Conference of IT4I National Supercomputing Center

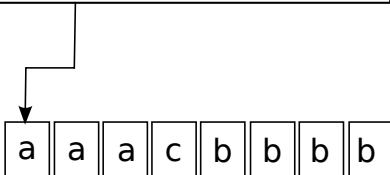
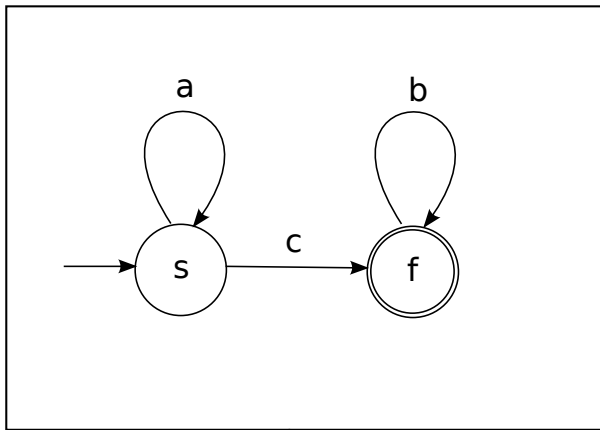

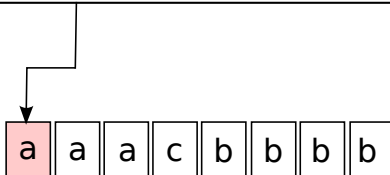
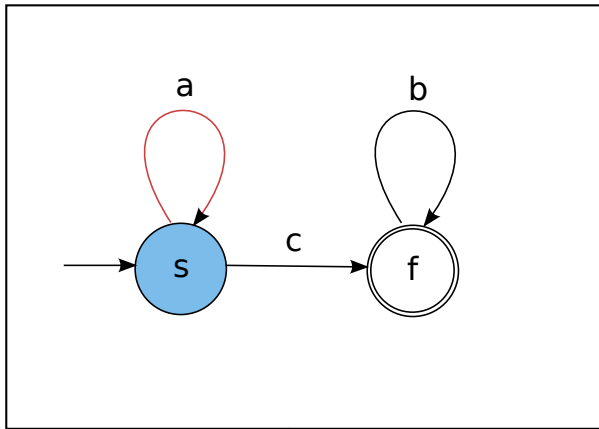

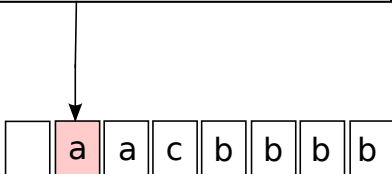
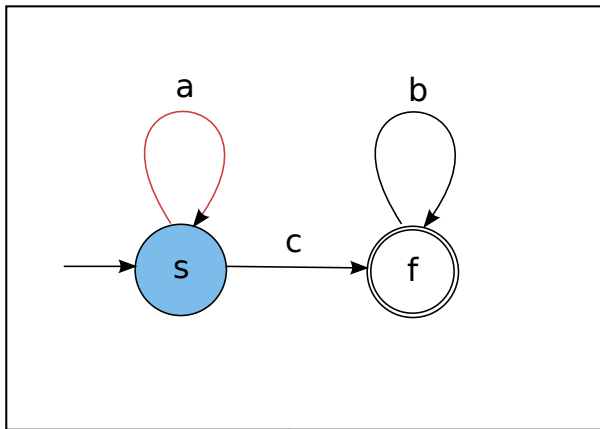

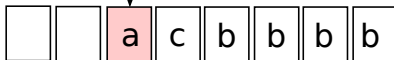
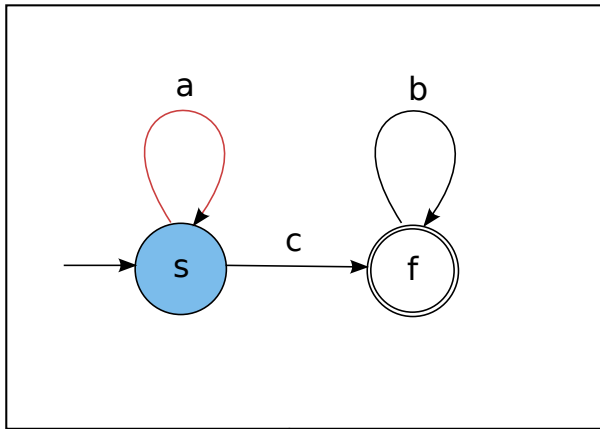

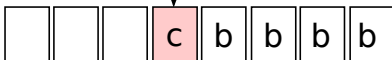
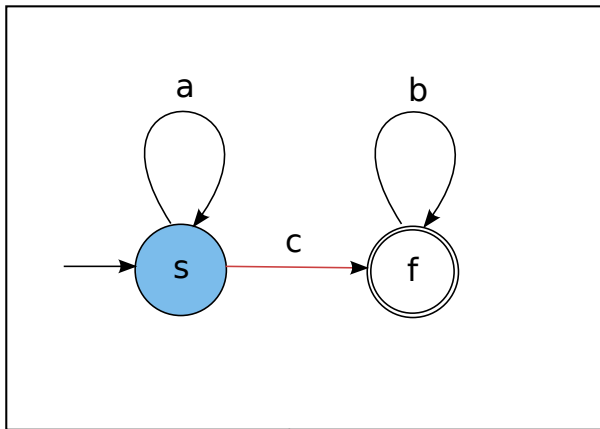

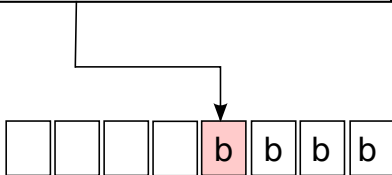
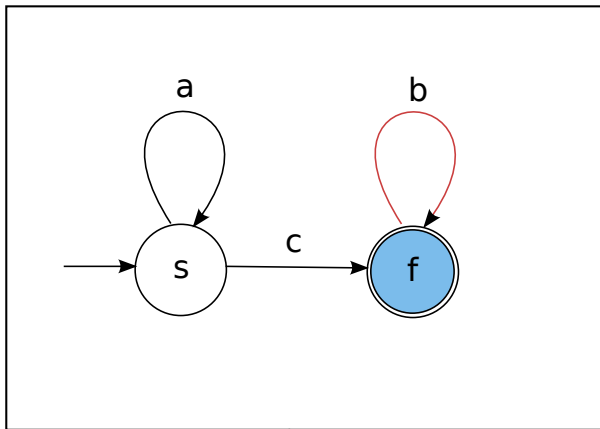

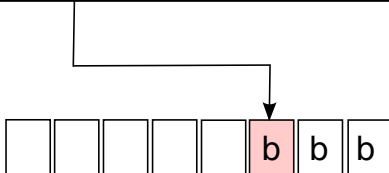
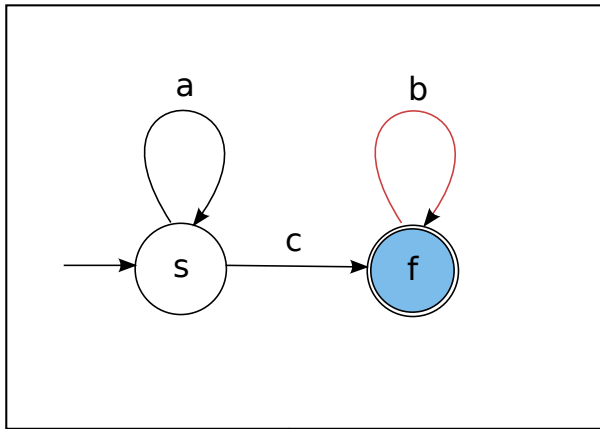

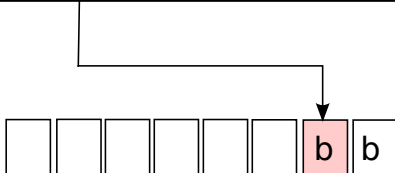
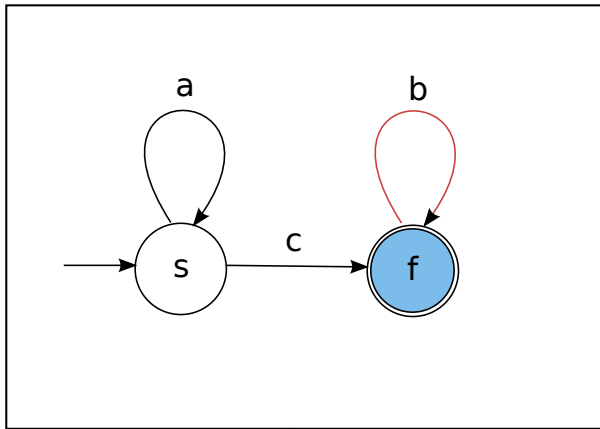

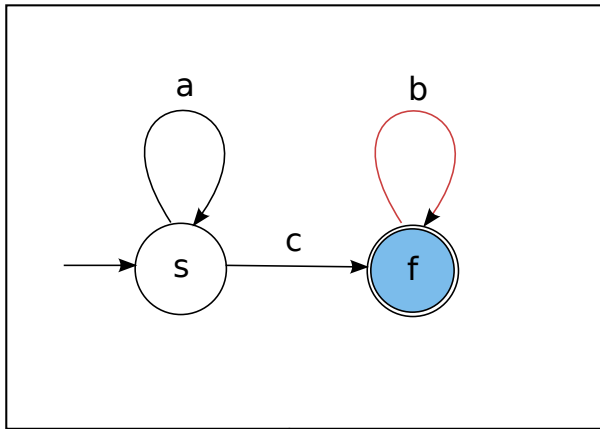

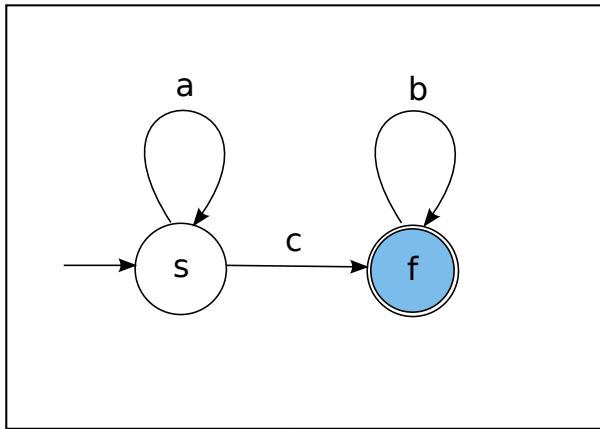

Accepted!



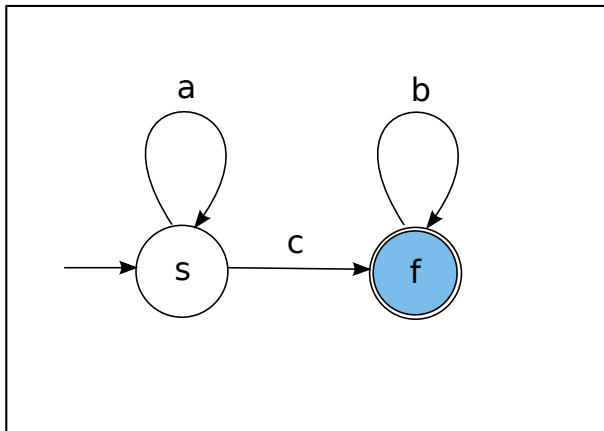

Accepted language: $\{a\}^* \{c\} \{b\}^*$

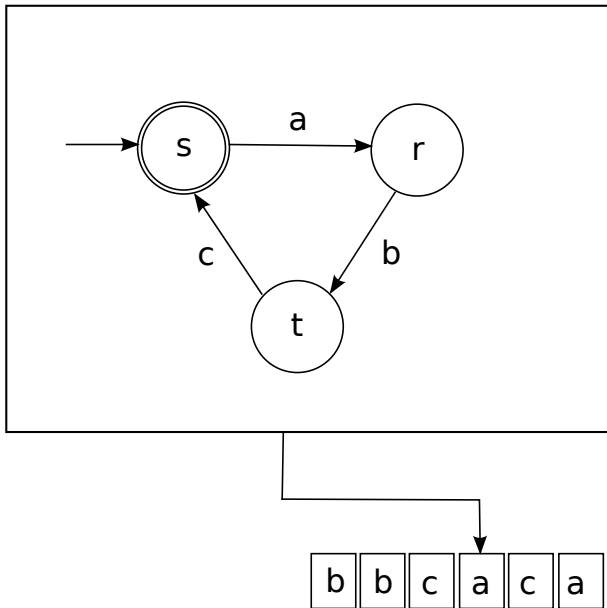

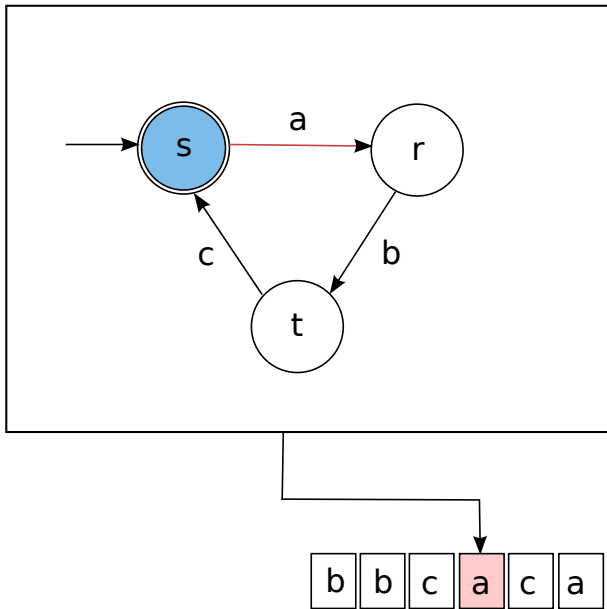

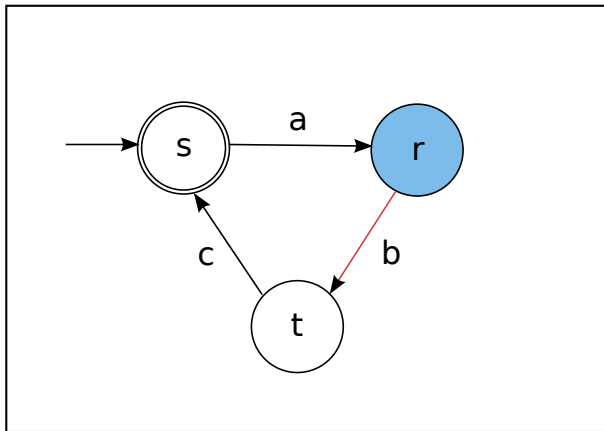

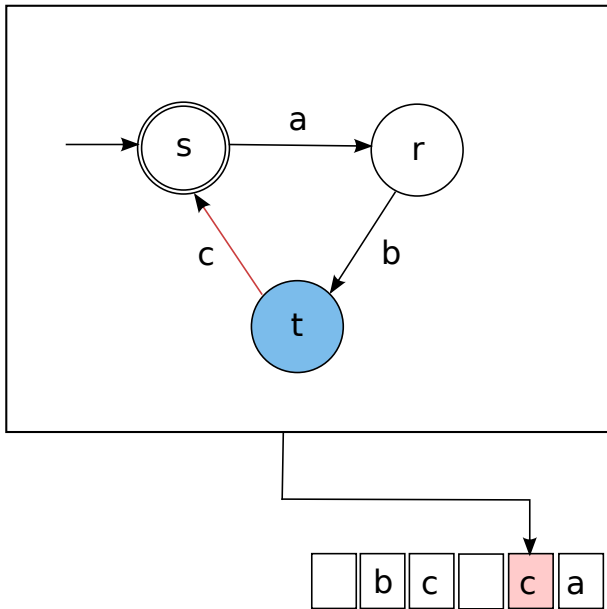

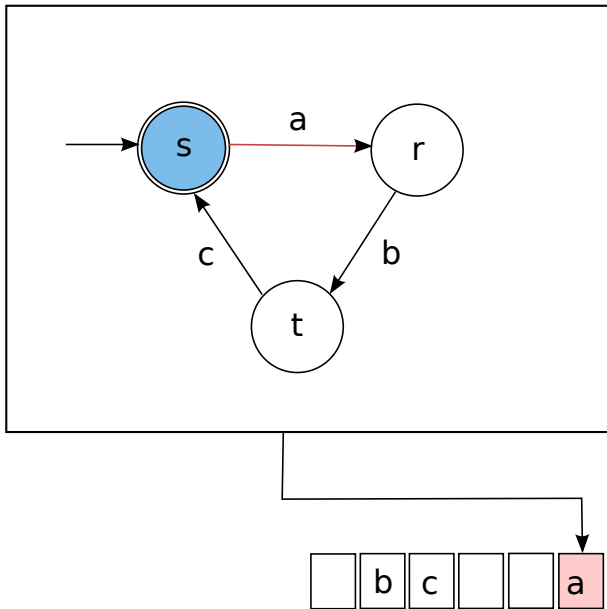

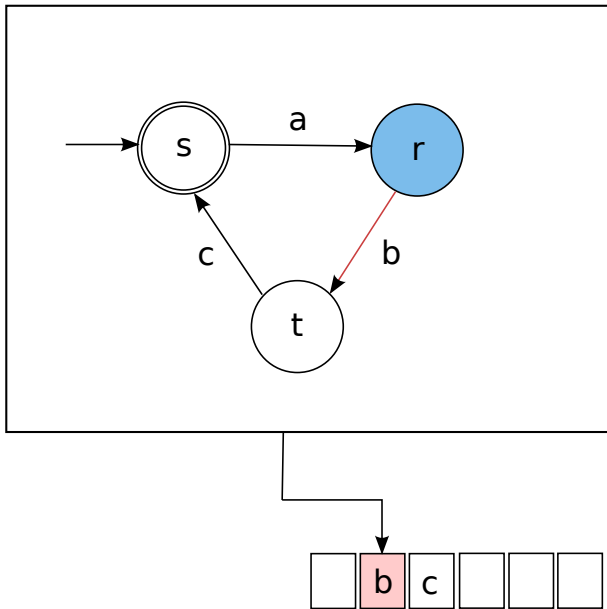

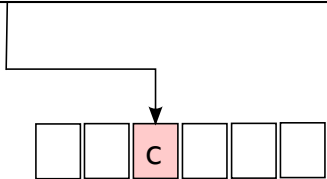
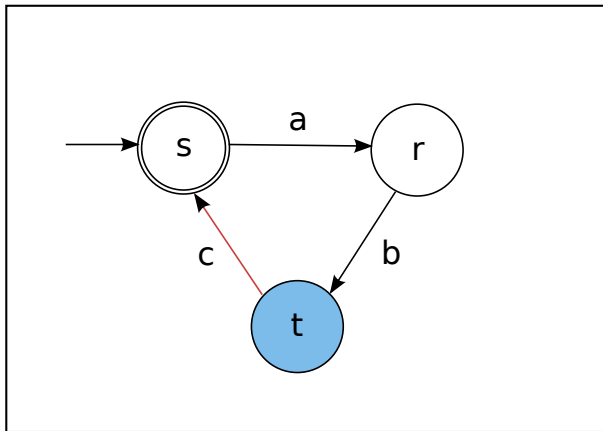

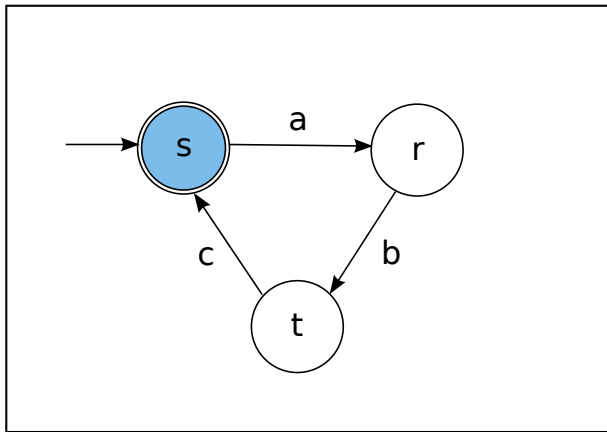

Accepted!



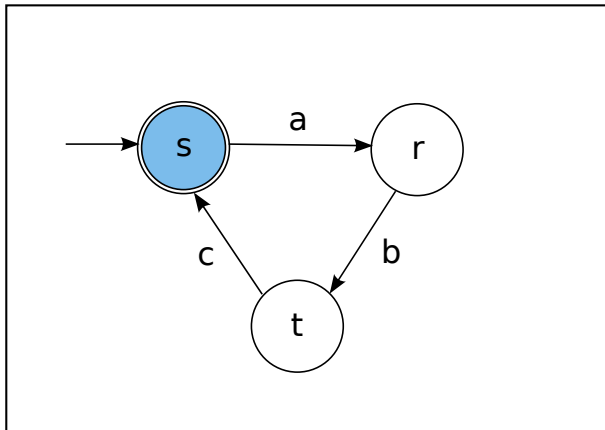

Accepted language: $\{w \in \{a, b, c\}^* : |w|_a = |w|_b = |w|_c\}$

Jumping Finite Automata (JFA)

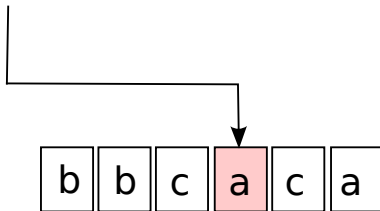

General Jumping Finite Automata (GJFA)

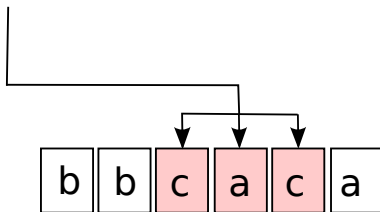

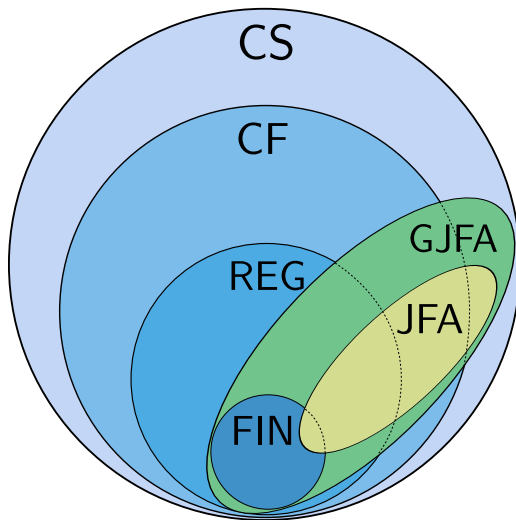

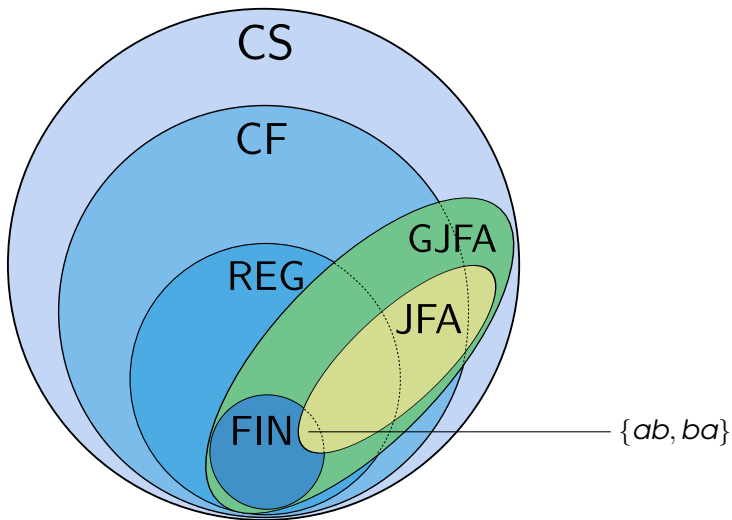

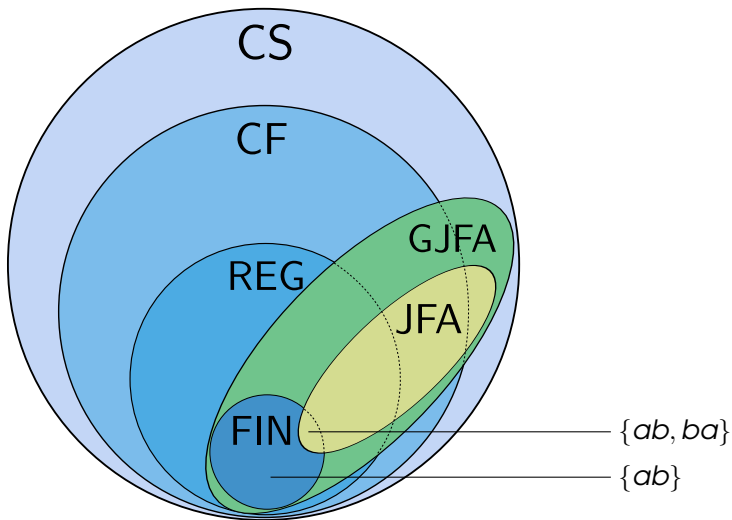

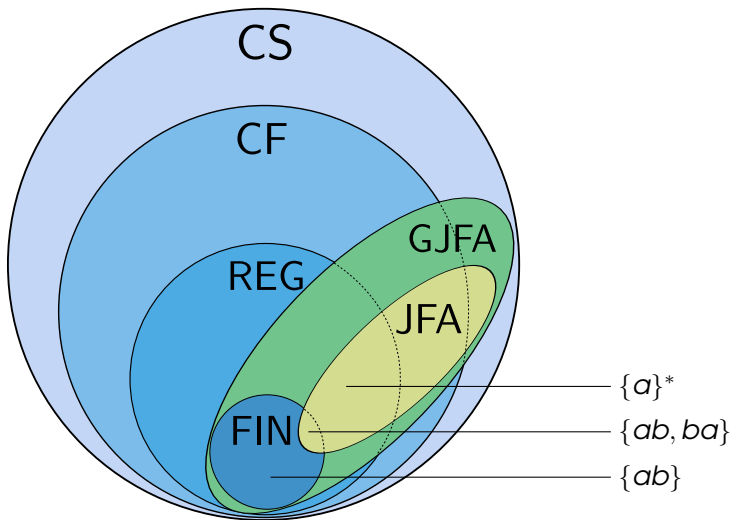

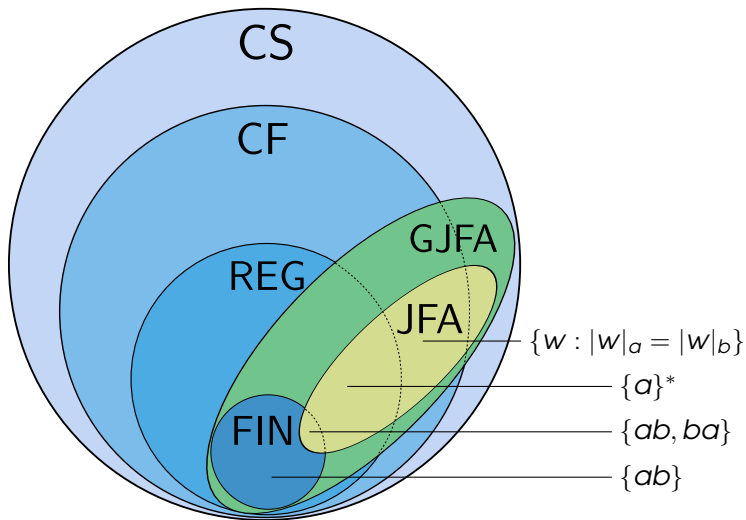

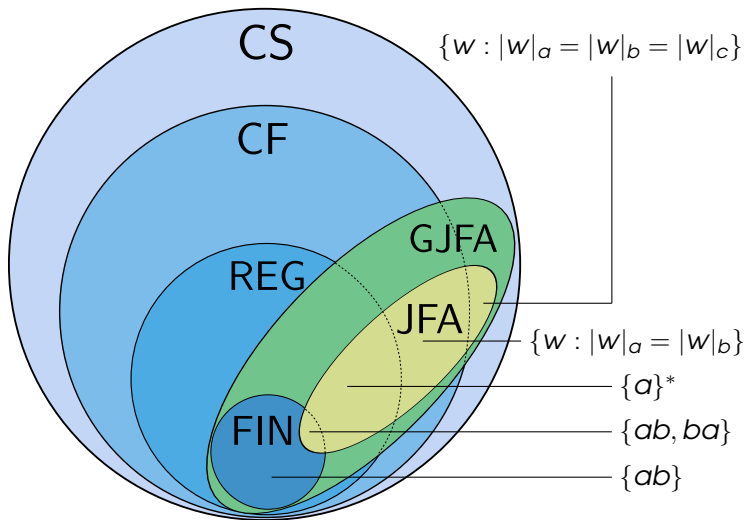

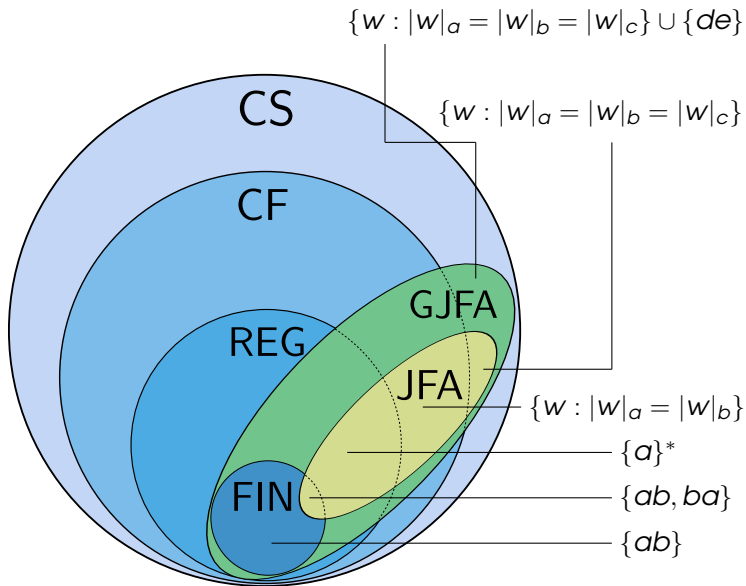

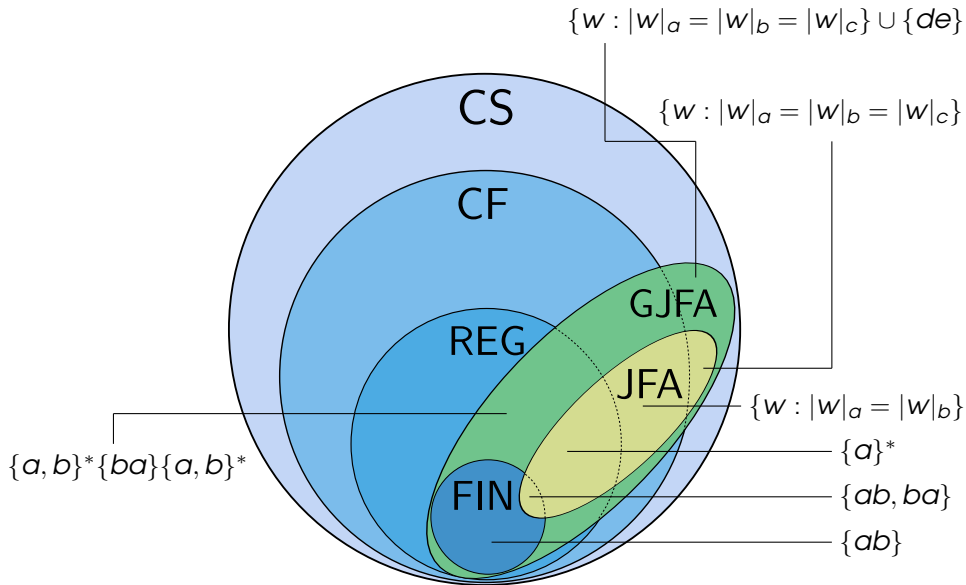

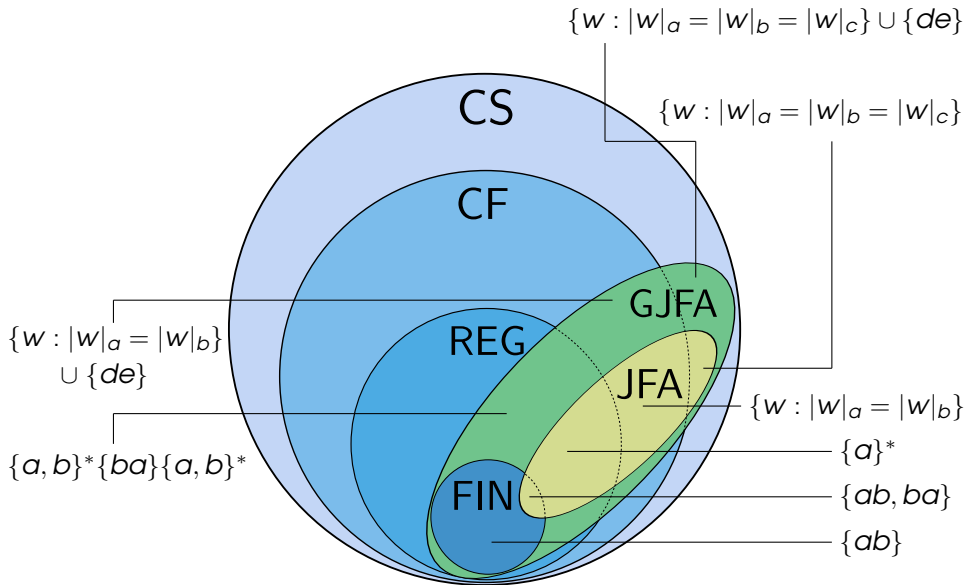

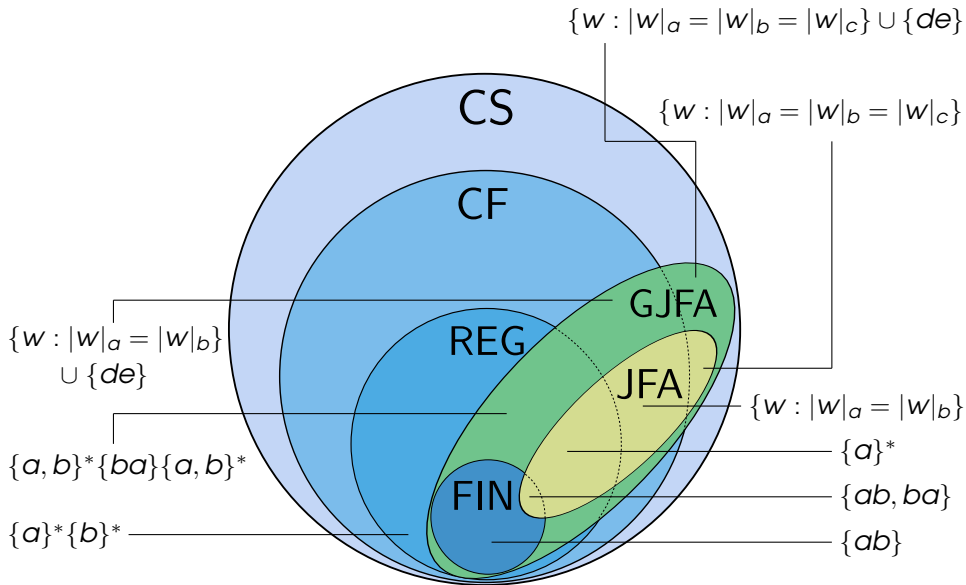

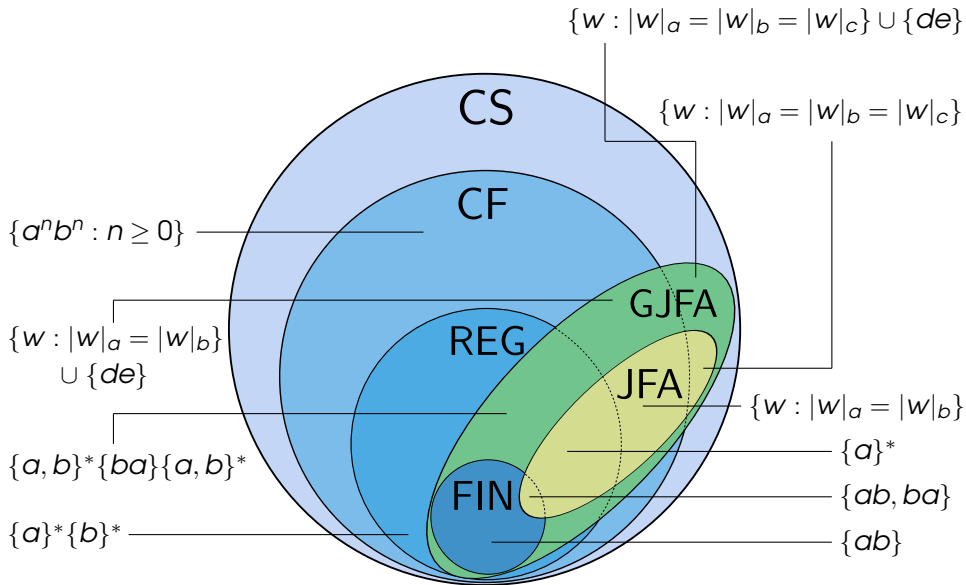

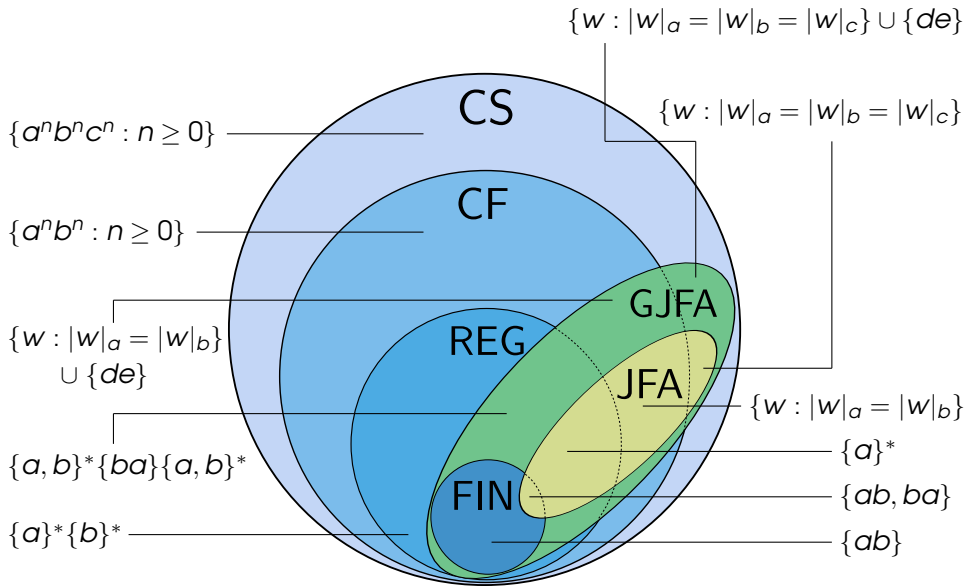

	GJFA	JFA	REG
union	+	+	+
intersection	-	+	+
concatenation	-	-	+
intersection with reg. lang.	-	-	+
complement	-	+	+
shuffle	?	+	+
mirror image	?	+	+
Kleene star	?	-	+
Kleene plus	?	-	+
substitution	-	-	+
regular substitution	-	-	+
finite substitution	+	-	+
homomorphism	+	-	+
ε -free homomorphism	+	-	+
inverse homomorphism	+	+	+



- decision problems



- decision problems
- *left* and *right* jumps



- decision problems
- *left* and *right* jumps
- an infinite hierarchy of language families



- decision problems
- *left* and *right* jumps
- an infinite hierarchy of language families
- a variety of start configurations



- decision problems
- *left* and *right* jumps
- an infinite hierarchy of language families
- a variety of start configurations
- making jumping finite automata deterministic



- decision problems
- *left* and *right* jumps
- an infinite hierarchy of language families
- a variety of start configurations
- making jumping finite automata deterministic
- application perspectives